



INDIAN SCHOOL AL WADI AL KABIR

Class: XI	Department: SCIENCE – 2020-2021	Date of Completion: 17.09.2020
	SUBJECT: <u>ENGINEERING GRAPHICS</u>	
Worksheet No:5 With Answers	Topic: <u>SECTIONS OF SOLIDS</u>	Note: A4 FILE FORMAT
NAME OF THE STUDENT:	CLASS: XI SECTION:	ROLL NO:

Questions

1. A sphere of 50 mm diameter resting on HP is cut vertically parallel to VP. Project its top view and sectional front view.

2. A square prism of 45 mm base edges and 45 mm height, resting on HP with all of its vertical rectangular faces, inclined to VP at 45 degree. It is sectioned horizontally 30 mm above its base. Project its front view and sectional top view.

3. A vertical pentagonal prism of 30 mm base edges and 50 mm height, resting on HP on its base with one edge of its base on the back side parallel to VP is sectioned by a plane perpendicular to VP inclined to HP at 60 degree towards the right. Project its front view and sectional top view.

4. A cone of 50 mm base diameter and 60 mm long horizontal axis, is resting on the HP with its vertical base at right angles to VP. It is sectioned by a horizontal plane, above its axis. Project its front view and sectional top view.

5. A triangular pyramid of 50 mm base edges and 60 mm long horizontal axis, is resting on one edge of its base which is at right angles to VP. It is sectioned by an oblique plane, inclined to HP towards the right. Project its front view and sectional top view.

6. A triangular pyramid of 50 mm base edges and 60 mm long horizontal axis, is resting on one edge of its base, which is at right angles to VP. It is sectioned by a horizontal plane above its axis. Project its front view and sectional top view.

7. A hexagonal prism of 25 mm base edges and 60 mm length is resting on one of its rectangular faces on the HP, with its hexagonal ends at right angles to VP. It is cut by an oblique plane inclined to HP towards the left and intersecting the axis at a point 20 mm away from one of its ends. Project its front view and sectional top view.

8. A cylinder of 50 mm base diameter and 60 mm long is resting on HP on its curved surface, with its circular ends at right angles to VP. It is sectioned by a horizontal plane, above its axis. Project its front view and sectional top view.

MULTIPLE CHOICE QUESTIONS

1. Which one of these cannot be obtained by sectioning a cone ?

- a) Parabola
- b) Circle
- c) Ellipse
- d) Square

2. When a vertical rectangle is revolved about one of its sides, its side will generate a -----

- a) Cylinder
- b) Cone
- c) Sphere
- d) Pyramid

3. When the axis of a regular solid is perpendicular to VP, then its base will be seen in :

- a) Front view
- b) Top view
- c) Side view
- d) None of the above

4. Which one of the following is not a principal plane of projection?

- a) HP
- b) VP
- c) PP
- d) None of these

5. A plan of an object is

- a) Left hand side view
- b) Top view
- c) Front view
- d) Right hand side view

MULTIPLE CHOICE QUESTIONS

ANSWERS

- 1.d) Square
- 2.a) Cylinder
- 3.a) Front view
- 4.c) PP
- 5.b) Top view

SOLUTIONS FOR DRAWINGS

1.

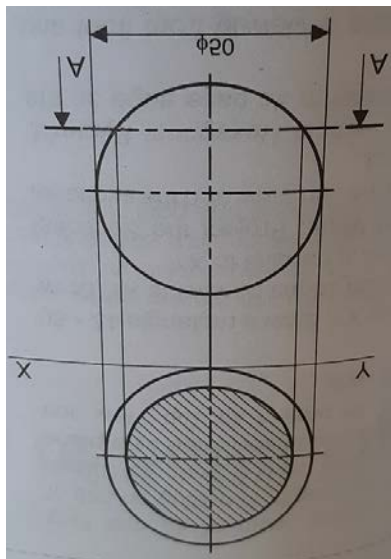

2.

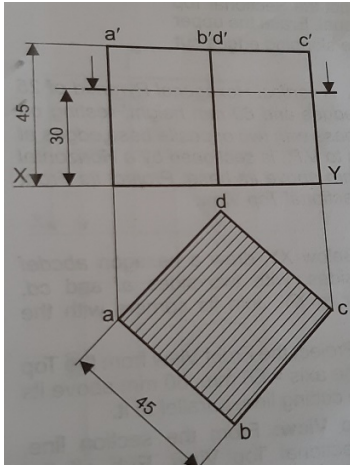

3.

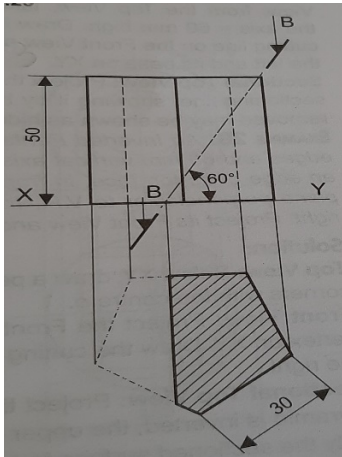

4.

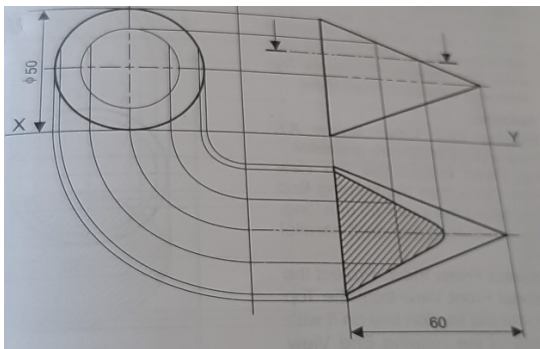

5.

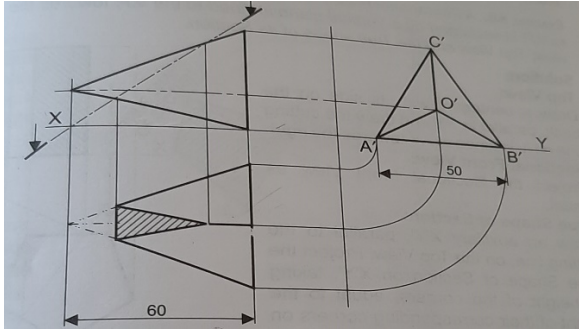

6.

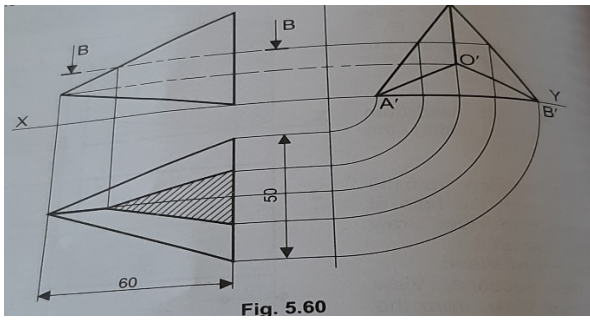

7.

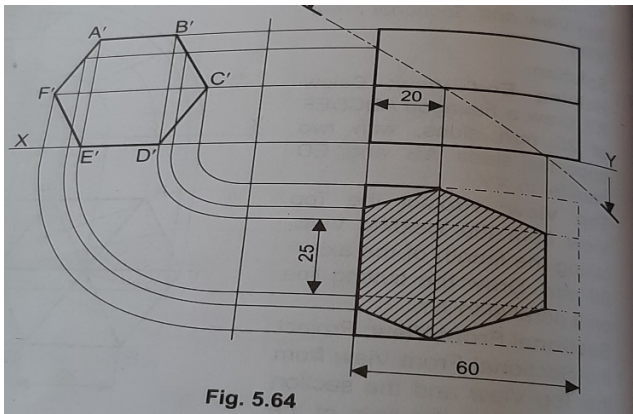

8.

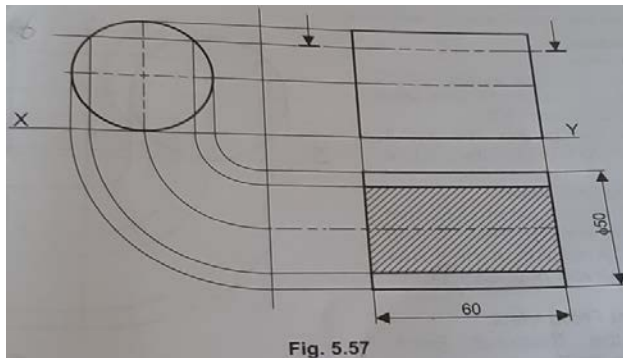

Prepared by,
Mrs.Aiswarya Deepthi.P

CHECKED BY: HOD - SCIENCE